

# BRAZING

## TIPS & TECHNIQUES



**LucasMilhaupt®**

A STEEL PARTNERS COMPANY



## Contents

The Many Uses of Brazing .....	3
The Nature of the Brazing Process .....	4
1: Good Fit and Proper Clearance .....	5
2: Cleaning the Metals .....	6
3: Fluxing the Parts .....	6
4: Assemble for Brazing .....	7
5: Brazing the Assembly .....	8
6: Cleaning the Brazed Joint .....	10
Some Things to Consider .....	10
Three Common Joints .....	11
Disassembling Brazed Joints .....	12
Safety in Brazing .....	13

## Product Charts

Brazing Alloys .....	14
Brazing Flux .....	19
Solders .....	20
Soldering Fluxes .....	22
Quick Reference Chart .....	23

## The Many Uses of Brazing

For many years, brazing has been the principal metal joining method used to fabricate heating, air conditioning and refrigeration equipment. Today, a typical HVAC unit may contain hundreds of brazed joints.

Brazing is used to join copper tubing to return bends, copper tubes to headers and fins, and tube bundles to shells. Brazing joins both similar and dissimilar metals, thin and thick sections, and metals of widely differing melting temperatures.

Brazing is so universally used in this industry because it's economical, easy to do and because it produces strong, leak tight joints. Leak tightness is especially critical in HVAC units because these are all closed systems; containing a liquid or gas as a heating or cooling medium. Leakage from any joint would allow the liquid or gas to escape, and prevent the unit from functioning properly.

These advantages, economy, strength and leak tightness are inherent in the brazing process.

# The Nature of the Brazing Process

We can define brazing as the joining of metals through the use of a heat and a filler metal. In this process the melting temperature of the brazing filler metal is above 840° F (450° C), but in all cases below the melting point of the metals being joined.

The brazing process consists of the broad heating of the base metals to the point where the filler metal, applied to the joint area, will be melted and drawn by capillary action through the entire joint. After cooling, the brazed joint constitutes a strong metallurgical bond between the filler metal and the two base metals.

Two outstanding characteristics of a brazed joint are its high strength, and the low heat at which it is made. A properly made brazed joint will generally be stronger than the metals being joined. And the temperature at which the joint is made is much lower than the melting temperature of the metals being joined.

A brazed joint “makes itself,” in the sense that capillary action, rather than operator manipulation, is responsible for flowing the filler metal completely through the joint. But even a properly designed joint can turn out imperfectly unless you follow correct brazing procedures. These procedures can be described as six basic steps.



## 1: Good Fit and Proper Clearance

The best clearance between the two metal parts being brazed is a close one – usually .001” to .003”, and generally not more than .005”. If the clearance is smaller than .001”, there may be no room for the molten filler metal to flow through the joint. And if the clearance is wider than .005” or .006”, capillary action is less effective and the filler metal may fail to fill the joint completely.

In the fabrication of HVAC equipment, achieving the proper clearance for brazed joints is seldom a problem. The design of the joint is predetermined – it’s almost always a “cup” design, in which one tube is inserted into the expanded end of another tube. As long as you start with tubing that’s round and manufactured to the correct dimensions, you can anticipate no clearance problems.

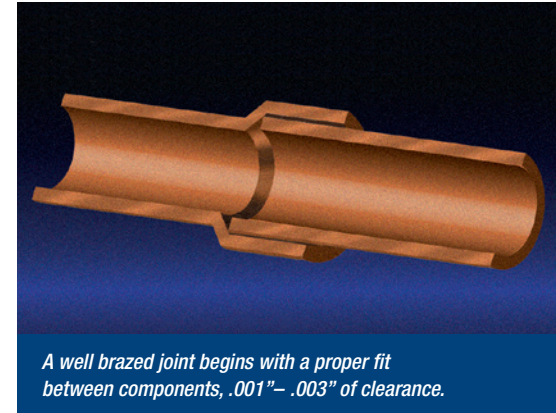

*A well brazed joint begins with a proper fit between components, .001”– .003” of clearance.*

However, you do have to give some care to the preparation of the tubes for brazing. For example, if you’re brazing a tube to a fitting, you’ll generally start by cutting the tube to the length you want. Make sure it’s cut square, by using a sawing vise or tube cutter, and remove the burrs. Slide the tube end into the fitting and check that it has the proper close fit – an easy slip fit.

The majority of brazed joints HVAC units are copper-to-copper joints. That means you don’t have to worry about the “coefficients of expansion” of the base metals – as the two copper parts will expand at the same rate. However, if you’re brazing joints of dissimilar metals (copper to steel) you have to take into consideration the different expansion rates.

You know that non-ferrous metals (copper, brass) expand more during heating than ferrous ones (steel, stainless steel). So, be sure to adjust the initial joint clearance accordingly. Where heating will reduce the clearance, for example brazing a copper tube to a steel header, start with a relatively loose fit (approx. .010"). Where heating will increase the clearance, start with a close or even force fit.

## 2: Cleaning the Metals

Capillary action, the basis of all brazing, can't work properly on dirty surfaces. If the surfaces of the metals are contaminated (with oils, dirt, etc.) the brazing filler metals will not adhere to them and the joint will fail.

In fabricating HVAC units, you're generally working with factory new tubing and parts. But if for any reason those parts have become dirty or greasy, you will have to clean them to insure a leak tight joint. Oil and grease can be removed with a solvent, then oxides can be removed by an abrasive like an emery cloth. Once the parts are clean, it's recommended to braze as soon as possible so the parts won't have time to become re-contaminated.



## 3: Fluxing the Parts

Flux is a chemical compound, usually made in the form of a liquid or paste which is applied to the joint surface prior to brazing. Its purpose is to protect the joint surface from the oxides that form during heating. Flux melts and becomes active during brazing, absorbing oxides and assisting in the flow of the brazing alloy.

Although fluxing is generally an important part of the brazing process, it plays only a minor role in brazing HVAC components because most of these joints are copper-to-copper. When brazing copper-to-copper you can eliminate the flux by using a phosphorus bearing filler metal like Sil-Fos® or Fos Flo® because the phosphorus acts as a fluxing agent.

However, when brazing copper to steel (in compressor or valve assemblies) you can't use phosphorus bearing filler metals as they form brittle phosphides and the joint could fail. Instead use a phosphorus-free filler metal (like the Silvaloy® family of alloys) but then you will have to use a flux. When brazing brass, you could use a phosphorus bearing alloy, but you will have to apply flux here as well.

Flux can be applied on to the parts being brazed with a brush, or it can be incorporated directly into the filler material in the form of flux cored or flux coated wire or rod. However the flux is applied, it is important that it does not get inside the parts where it could contaminate the system.

## 4: Assemble for Brazing

Before the parts can be heated and brazed, they have to be aligned and then supported. This is typically not an issue when brazing HVAC components since virtually all the joints are tubular, slip-fit assemblies. By their nature, they are self-aligning and self-supporting during the brazing process.

When assembling, make sure there is full insertion of one tube into the other before brazing. The distance of insertion should be equal to the inside diameter of the inner tube section.

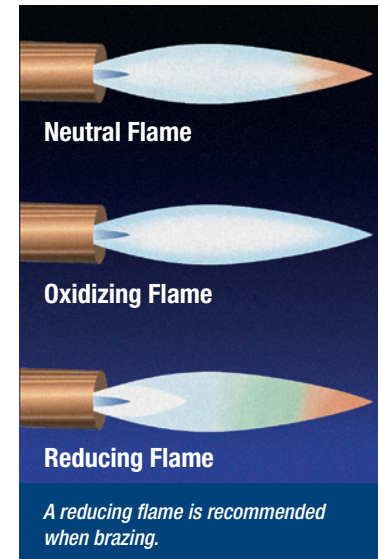

## 5: Brazing the Assembly

The actual brazing operation is a two-part process: first, heating the base metals and second, applying the filler metal to the joint.

Regardless of the heating equipment being used, be sure to heat both base metals broadly and evenly, so the filler metal will wet equally well on both metal surfaces and completely fill the joint. Because of the wide variety of joints and joint locations, the gas-air torch is frequently used as the heat source. A soft flame provides the best type of heat.

When brazing a tube to a fitting, or into another tube of larger diameter, the following procedures should be followed:

Adjust the torch for a reducing flame (one that contains more fuel gas than oxygen). The flame should be soft enough and large enough to envelop both the tube and fitting.

Start heating the tube about an inch away from the end of the fitting, then shift the heat to the fitting. Sweep the heat steadily back and forth from tube to fitting, with most of the heat being applied to the heavier (and slower to heat) fitting.

Heat the assembly until it reaches brazing temperature. If the part has been fluxed with Handy Flux, the flux will become clear or transparent at this temperature. If you have not used flux, you'll know you're at brazing temperature by the dull red color of the metals being heated.

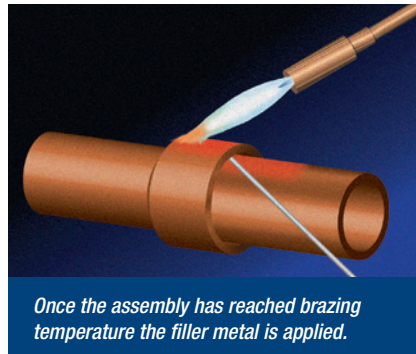
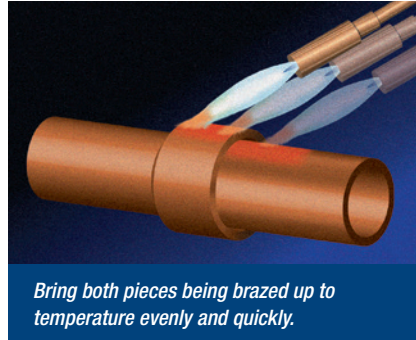

At this point, pull the flame back a little and apply the filler metal firmly against the tube at the junction of the tube and fitting. If you are using a phosphorus-bearing alloy, lay the rod on and wipe it around the joint, as these alloys tend to flow sluggishly. If the joint has been properly heated, the filler metal will melt, penetrate and completely fill the joint.

After the joint has been completed, make one final pass of the flame at the base of the joint, and even twist the joint if possible, to expel any entrapped gas or flux and to provide maximum wetting by the filler metal.

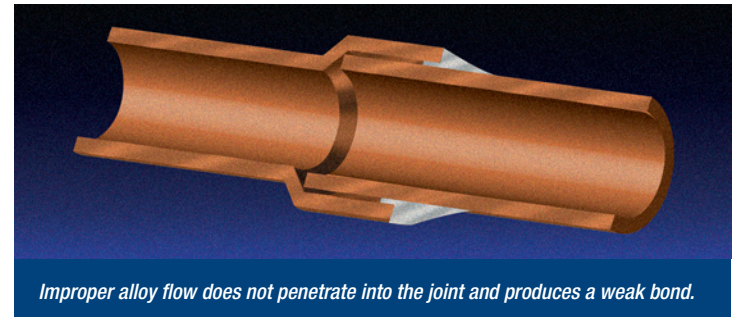
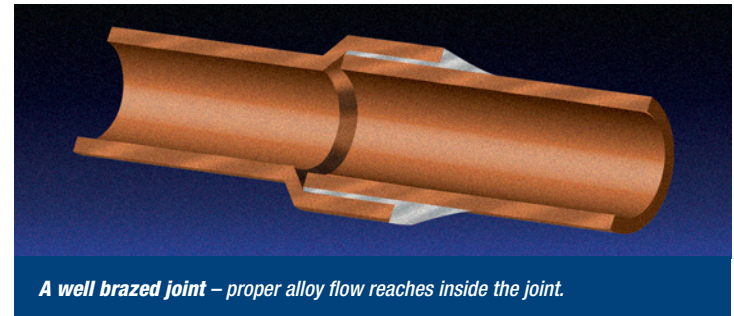

## 6: Cleaning the Brazed Joint

Generally speaking, brazed joints in HVAC units require no post braze cleaning operations. However, in the minority of cases where flux has been used, it may be necessary to remove the flux residues after the joint has set. A hot water wash, assisted by brushing or swabbing usually does the job. If necessary, you can remove more stubborn residues with a wire brush.

## Some Things to Consider

When you're heating an assembly for brazing, you want to heat the joint area as rapidly and as uniformly as possible. So in those instances where you're joining metals of unequal mass and thickness you'll have to apply some extra heat to the heavier section which heats more slowly. And where you're joining dissimilar metals with differing heat conductivity (copper to steel), you'll have to apply proportionally more heat to the copper, since copper is a better conductor and carries heat away more rapidly to the colder sections. In no case, of course, should the metals be heated to the point where they begin to melt.



## Three Common Joints

The brazing techniques described will vary somewhat depending upon the kind of joint you're making. The three common tube-to-fitting joints used in HVAC components are the vertical down, the vertical up and the horizontal joint. The following procedures are recommended for each of these joints:

**Vertical down joints:** Bring the entire joint area up to temperature quickly and uniformly, heating the tube first, then the fitting. When the joint area has reached brazing temperature, apply a little extra heat to the fitting, since this is the direction in which you want the filler metal to flow.

**Vertical up joints:** Start by heating the tube. When it has reached a temperature of about 800° F (425° C) transfer the heat to the fitting. Then sweep back and forth from fitting to tube, all around the joint area. Be careful not to overheat the tube below the fitting, as this would encourage the filler metal to run down the tube and out of the joint. When brazing temperature is reached, touch the filler metal to the joint with the flame on the wall of the fitting. This heating pattern will draw the filler metal up and completely through the joint area.

**Horizontal joints:** Preheat the tubing and fitting quickly and evenly. When brazing temperature is reached, apply the filler metal to the top of the joint. The combination of gravity and capillary action will draw the filler metal completely around the tube to its bottom. You can apply a slight excess heat to the bottom of the fitting to insure that the filler metal totally penetrates the joint. Check the joint face to be sure filler metal is visible all around it. In particular, make sure that filler metal shows at the top of the joint. If it does not, apply some additional filler metal until it is visible all around the joint.

## Disassembling Brazed Joints

At some time you may find it necessary to disassemble a braze joint. The procedure to accomplish this is a simple one. You first flux the joint area completely. Fluxing will help the filler metal to flow at virtually its original flow point, and it will also keep the parts clean for rebrazing. After fluxing, heat the joint evenly to slightly higher than the melting temperature of the filler metal. At this point, the two components can be easily separated. Later on, you can rebraze the assembly by following the same six steps, however it's generally necessary to apply some additional brazing filler metal when you're rebrazing a disassembled joint to compensate for the filler metal lost in disassembly. If any additional filler metal is used, it should be the same composition as the original braze.

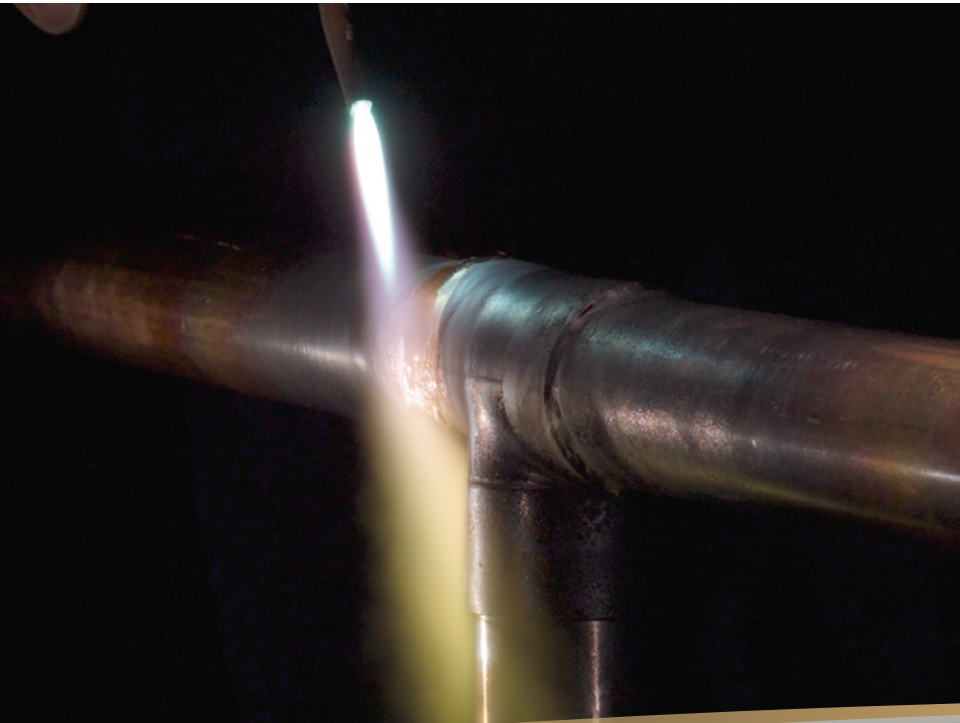

## Safety in Brazing

In brazing there are two possible sources of hazard to brazing operators. One consists of chemical fumes, and the other the heat and rays of the torch flame. The following general precautions should be taken to guard against these hazards.

### Fumes:

Ventilate confined areas, using fans, exhaust hoods or respirators if necessary. Clean all base metals to remove surface contaminants that may create fumes when the metals are heated. Use flux (where required) in sufficient quantity to prevent oxidation and fuming during the heating cycle.

Heat broadly, and heat only the base metals – not the filler metal. Remove any toxic coatings and be careful not to overheat assemblies.

### Torch Heat and Rays:

Operators should wear gloves to protect hands against heat. Shaded goggles or fixed glass shields protect operators against eye fatigue and vision damage.

For a detailed discussion of safety factors, consult the National Standards Z49.1 “*Safety in Welding and Cutting*” published by the American Welding Society (AWS)  
550 N.W. LeJeune Road  
P.O. Box 351040, Miami, FL 33135



## High Silver Brazing Alloys

### For joining ferrous and non-ferrous materials.

In refrigeration applications, much of the brazing involves joining copper tubing. However, there are numerous applications where other materials need to be joined (steel, brass, stainless, etc.). These high silver brazing alloys facilitate the joining of these metals. The one alloy in particular which is highly recommended for virtually all the above-mentioned base metals is Silvaloy® 505. It's advantages over 56% and 45% include:

- It contains 2% Nickel which enhances wetting and strength and facilitates the joining of steels, stainless steel, carbide, etc.
- The flow characteristics can be easily manipulated by either fast or slow heating techniques—this allows bridging of gaps.
- It's available in flux-cored and coated rod for added convenience and ease-of-use: No separate fluxing operation required.



Name	Description	AWS Spec	Composition %					Temperature °F	
			Ag	Cu	Zn	Sn	Other	Melt	Flow
Silvaloy® 560	Lowest temperature, Cadmium-free filler metal	BAG-7	56	22	17	5		1145°	1205°
Silvaloy® 505	Best general purpose filler metal available. Recommended for stainless steel (as it retards/eliminates interface corrosion) Nickel content provides superior adhesion ("wetting") to base metal surfaces.	BAG-24	50	20	28		2 Ni	1220°	1305°
Silvaloy® 452	Low temperature, general-purpose alloy with better flow properties than Braze 450.	BAG-36	45	27	25	3		1195°	1251°
Silvaloy® 450	General purpose filler metal for joining ferrous, non-ferrous and dissimilar metals with large joint clearances. Cadmium-free.	BAG-5	45	30	25			1225°	1370°
Silvaloy® 401	A more economical filler metal with a fairly narrow melt range, this alloy has application for both steel and copper-based materials.		40	30	30			1245°	1340°
Easy Flo® 45	Versatile alloy, used for most ferrous and non-ferrous metals. Contains Cadmium—therefore exercise extreme caution as Cadmium fumes are toxic.	BAG-1	45	15	16		24 Cd	1125°	1145°

Product Availability: .062" diameter wire standard, however, other sizes are also available.

Packaging Options: 1 and 5 troy ounce spools  
50 oz. "boxed" coils  
Silvaloy 505, 560 and 452 also available as Flux-coated rod

## Handy One®

### Flux-cored brazing alloys

Handy One is a brazing alloy in strip form that is rolled around a powdered flux. This simplifies and improves the brazing operation by eliminating the separate fluxing operation, and by delivering the correct amount of flux – right where it's needed.

Other benefits include:

- A reduction in the brazing cycle time
- Improved joint strength and quality
- Minimizes post braze cleaning
- Reduces flux contamination



Name	Description	Composition %					Temperature °F	
		Ag	Cu	Zn	Sn	Ni	Melt	Flow
Silvaloy® 505	Best overall general purpose alloy. Joins all common metals (except aluminum) including stainless steel. Fast flow.	50	20	28		2	1220°	1305°

Flux cored alloys are available in tubes containing 8 sticks of .075 diameter wire in 20 inch lengths



## Sil-Fos® Family of Brazing Alloys

### For Joining Copper and Copper-based Alloys.

This group of alloys allows the joining of copper to copper without a flux and copper based alloys (brass and bronze) with a flux. The family of products includes the original Sil-Fos® 15. Developed and patented over 80 years ago, Sil-Fos is the workhorse filler metal used in the refrigeration and air conditioning industry.

The ductility factor is more important than just convenience. Think of the brazing alloy as the glue that holds the refrigeration system together. The thermal cycling (and subsequent expansion and contraction), vibration stresses and higher pressures of the new refrigerants strongly suggest that the ductility of the braze alloy is extremely important—not just for an initial leak tight joint, but to be hermetic for many years down the road.

LucasMilhaupt®  
**SIL·FOS®**  
 THE ORIGINAL  
 1931  
 LUCAS-MILHAUPT



Name	Description	AWS Spec	Composition %			Temperature °F	
			Ag	Cu	P	Melt	Flow
Sil-Fos® 15	Best alloy for general copper-copper brazing in the Sil-Fos family. For copper-to-copper joints the phosphorus in the Sil-Fos product serves as the fluxing agent and no separate flux is necessary. For brass applications however, flux is recommended. For use where close fit-ups cannot be maintained Sil-Fos 15 works well to "bridge" gaps. Highest joint ductility of the entire Sil-Fos family to best withstand the stresses inherent in refrigeration applications. Slow Flow.	BCuP-5	15	80	5	1190°F	1475° (1300°)
Handy-Flo® 6	Recommended for use where a close fit-up cannot be maintained. Has the ability to fill gaps and form fillets without affecting joint strength. Slow Flow. (formerly Sil-Fos® 6M)		6	88	6	1190°	1460° (1300°)
Sil-Fos® 5	Designed primarily for those applications where close fit-ups cannot be maintained. It has the ability to fill gaps and form fillets without adversely affecting joint strength. Slow Flow.	BCuP-3	5	89	6	1190°	1495° (1325°)
Sil-Fos® 2	A filler metal with comparable characteristics to Fos-Flo. Medium Flow.	BCuP-6	2	91	7	1190°	1450° (1325°)
Fos Flo®	An economical, very fluid medium temperature filler metal for use with copper, brass and bronze. Withstands moderate vibration. Fast Flow.	BCuP-2		92.8	7.2	1310°	1460° (1350°)

## Flux Coated Brazing Alloys

Lucas-Milhaupt offers several brazing materials with a coating of flux on the outside of the rod. Brazing Rods are 18 inches in length and sold per quarter pound tube.

Name	Description	Composition %						Temperature °F	
		Ag	Cu	Zn	Sn	Ni	Other	Melt	Flow
Silvaloy® 560	Lowest temperature, cadmium-free filler. Very fluid alloy joins ferrous and non-ferrous metals	56	22	17	5			1145°	1205°
Silvaloy® 505	General purpose filler for joining all common metals (except aluminum) including Stainless Steel	50	20	28		2		1220°	1305°
Silvaloy® 452	Low temperature, general-purpose filler metal with better flow properties than Braze 450.	45	27	25	3			1195°	1251°



## Handy® Flux

Where fluxing is required as part of the brazing operation, Handy Flux is recommended. Handy Flux is an all-purpose flux for use in brazing both ferrous and non-ferrous metals and alloys. Where larger mass assemblies are being joined, Black Flux is often recommended as it offers higher temperature protection.

Handy Flux (White)  
Conforms to:  
AWS Brazing Flux Type FB3A  
AMS-3410

Handy Flux Type B-1  
Conforms to:  
AWS FB3-C  
AMS 3411

Handy Liquid Flux  
AWS FB3-E



Packaging Options:  
Handy Flux is available in a 7 oz. jar with brush cap, 1/4# and 1/2# jar.

Both Handy Flux and Handy Flux Type B-1 are available in 1#, 5#, 25#, and 50# containers.

Handy Liquid Flux available in pints, quarts and gallons.

## Ultra Flux®

Premium grade general application silver brazing flux. For use on all metals except aluminum, magnesium, and titanium. Fully molten at 1100°F, effective to 1600°F. Like all Lucas Milhaupt fluxes, Ultra Flux is manufactured to the highest quality standards to assure consistently outstanding performance.

Ultra Flux Conforms to:  
AWS A5.31 FB3A  
SAE AMS-3410  
Fed Spec O-F-499 Type B



Packaging Options:  
Ultra Flux is available in a 7 oz. jar with brush cap, 1# and 5# jar.

## Black Flux™

Black Flux is a boron modified, water based active fluoride/borate-type flux in paste form, which has been specially formulated to give excellent adhesion when dipped or brushed on parts. It is recommended to use with filler metals that flow between 1050°F (565°C) - 1800°F (982°C) and specifically formulated to ensure a creamy consistency. The flux provides excellent protection of parts up to 1800°F (982°C).

Black Flux Conforms to:  
AWS A5.31 FB3C  
SAE AMS-3411  
Fed Spec O-F-499D, Type B



Packaging Options:  
Black Flux is available in a 1# and 5# jar.

### Lead-Bearing Solders

Low-temperature, tin/lead solders. Available with Rosin, Acid and solid cores.

Name	Description	Composition %		Temperature °F	
		Sn	Pb	Melt	Flow
50/50	Standard general purpose Tin/Lead solder for moderate joint clearances. Available as Solid, Acid or Rosin core.	50	50	361°	421°

Product Availability: .125" diameter x 1 pound spool, 1/4 pound, 1/2 pound and 1 pound tribar

Packaging Options: 12 pounds per case



### Silver-Bearing, Lead-Free Soft Solders

High strength—general purpose solders. Higher strength than Tin/Lead solders and safe for potable water systems.

These alloys are widely used in low-stress, low-pressure copper-copper and copper-steel applications (e.g. sight glasses where temperature must be kept low, etc.). For copper-copper, Silvabrite Paste Flux is the flux of choice. For copper-steel applications, TEC Liquid Flux is recommended as it is more aggressive at keeping the metal surfaces to be joined free of oxides. TEC is a more corrosive flux however, and subsequent flux residue removal is recommended.

Name	Description	Composition %				Temperature °F	
		Ag	Cu	Sn	Other	Melt	Flow
Silvabrite® 6	Lead-free, silver-bearing high-strength solder used for applications requiring large joint clearances. Easiest Silver-bearing soft solder to work with as temperature range permits "bridging" loose fit-ups if necessary.	6		94		430°	535°
Silvabrite®	Lead-free, silver-bearing high-strength solder used for applications requiring close joint clearances.	4		96		430°	430°
Silvabrite 100®	Silver-bearing solder with good strength used in potable water system applications requiring no lead.	0.4	4	95.6		440°	660°
Silvabrite® S	Ideally suited to applications where the added silver produces a plastic range during melting	5		95		430°	473°
95/5	General purpose Tin/Antimony solder. Not for use on brass alloys.			95	5 Sb	450°	464°

Product Availability: .125" diameter x 1 pound spool (1 Per Box)

Packaging Options: 24 pounds per case

### Handy One® Aluminum Braze and Solder

Flux cored low-temperature braze or solder for joining aluminum and aluminum to copper

Name	Description	Composition %		Temperature °F	
		Zn	Al	Melt	Flow
AL 822	Flux cored braze	78	22	800°	900°

Packaging Options: Sold in tubes of 4 sticks



**SEE AL-822 VIDEO & HOW TO USE IT!**

## Solder Fluxes

For soldering applications we offer two different flux products depending on the materials to be joined. They include Silvabrite® Flux for general purpose applications and TEC Liquid Flux where more aggressive fluxing is required for the more difficult-to-solder materials (e.g. steel, stainless steel, etc.).

Silvabrite® Paste Flux

TEC Liquid Soldering Flux

Packaging Options: 4 oz. jar with brush cap (Clean 'n Brite only)  
4 oz. squeeze bottle, pints, quarts and gallons (TEC only)



**Warning!** Brazing can generate potentially harmful fumes and gases. Protect yourself and others. Obtain a Material Safety Data Sheet (MSDS) from your supplier or from Lucas-Milhaupt, Inc. Follow the MSDS' instructions for safe brazing practices and appropriate measures.

*Warranty Clause: Lucas-Milhaupt, Inc. believes the information contained herein to be reliable. However, the technical information is given by us without charge and the user shall employ such information at his own discretion and risk. We assume no responsibility for results obtained or damages incurred from the use of such information in whole or in part.*

Base Metals to be Joined	Filler Metal to be Used	Proper Flux Selection	Comments
Copper or Brass TO Copper or Brass	<b>SOLDER WITH:</b> Silvabrite® 6 Silvabrite® S Silvabrite 100® Silvabrite® S  <b>BRAZE WITH:</b> Sil-Fos® 15 Handy-Flo® 6 Sil-Fos® 5 Sil-Fos® 2 Fos-Flo® (0% Ag)	Silvabrite® Flux or TEC Flux   These alloys are self-fluxing on copper, but Handy Flux® is needed for brass.	<b>Silvabrite® 6</b> is alloy of choice. It is lead free, contains 5.6% silver and can be made to exhibit either fluid or sluggish characteristics.  <b>Sil-Fos® 15</b> is the #1 choice by contractors, due to its greater ductility and ability absorb vibration stresses, etc. Due to potential for brittle iron-phosphide formation, these alloys are not recommended for brazing steel or other ferrous alloys.
Copper or Brass TO Steel	<b>SOLDER WITH:</b> Silvabrite® 6 Silvabrite® S Silvabrite®  <b>BRAZE WITH:</b> Silvaloy® 560 Silvaloy® 505 Silvaloy® 450 Silvaloy® 401	TEC Flux TEC Flux   Handy Flux® Handy Flux® Handy Flux® Handy Flux®	<b>Silvabrite® 6</b> used with the more aggressive <b>TEC Liquid Flux</b> is the recommended choice  <b>Silvaloy® 505</b> is fast becoming the alloy of choice because it offers higher strength, better corrosion resistance and better "wetting" to steel and stainless steel especially.
		Silvaloy® 560 Flux Coated or Flux Cored Silvaloy® 505 Flux Coated or Flux Cored Silvaloy® 452 Flux Coated Silvaloy® 380 Flux Cored	
Copper, Brass or Steel TO Stainless Steel	<b>SOLDER WITH:</b> Silvabrite® 6 Silvabrite® S Silvabrite®  <b>BRAZE WITH:</b> Silvaloy® 505	TEC Flux TEC Flux   Handy Flux®	<b>Silvabrite® 6</b> used with the more aggressive <b>TEC Liquid Flux</b> is the recommended choice.  We always advise using a nickel-bearing alloy to eliminate corrosion. <b>Silvaloy® 505</b> is an excellent choice.
		Silvaloy® 505 Flux Coated or Flux Cored	
Aluminum TO Aluminum or Copper	Al 822 Flux Cored Aluminum		High strength, low temperature braze for joining aluminum to aluminum and aluminum to copper. Easy to use, contains a non-corrosive flux.



5656 S. Pennsylvania Ave.  
Cudahy, WI 53110, USA  
Phone: (414) 769-8824 • (800) 521-5490

---

235 Kilvert Street  
Warwick, RI 02886, USA  
Phone: (401) 739-9550 • (800) 225-2130